

Instruction Manual & Repairing Guide

MODEL : HS4570 PLUS



HANSIN SPECIAL EQUIPMENT CO.

Contents

1. Introduction	2
2. General Precautions when using the equipment	3
3. Composition and Specifications	
A. Main composition and functions	4~5
B. Features of HS 4570	6
C. Diagram of Equipment Composition	7~8
D. Working Radius Diagram	9
E. Hyd' Component & Circuit	10
F. Connective Diagram of Electricity	11~12
4. Safety Rules	
A. Precaution before Operation	13
B. Precaution of Outrigger Operation	13
C. Precaution of Operator	14
D. Precaution During Equipment operation	14~15
5. Operation and Usage of HS 4570	
A. Operation preparation	16
B. Equipment preparation in hard winter	16
C. Equipment Operation of Function Section	16~23
6. Repair Precaution & Examination	
A. Check Points before Operation	24
B. Check Points during the Operation	24
C. Check Points after Operation	24
D. Check Points after 1month Operation	25
E. Check Points after 6months Operation	25
F. Lubrication	26
G. Examination & Exchange of the Hydraulic pressure oil	26
H. Exchange & Examination of Filter	27
I. Cylinder of Exchange	28~29
7. Malfunction & Measurement	30~31

1. Introduction

Thank you for buying Hansin HS series!

This guide Book is all about HS 4570 PLUS, it helps you to provide all necessary materials to be used effectively and safely for equipment users.

This also gives you the summary, description of data, equipment repair information and preparation which explained the procedure operation for management of equipment designed for Aerial Lift Truck.

However, If you want your equipment last, you should follow this guide to prevent failure. So, apparently HS4570 plus operate to secure lifetime use.

Prior HS4570 plus, you must follow all the guides for your safety. If you find any difficulties while using this guide or if you have any questions, feel free to contact the dealer.

In addition, if you want to request some parts you are required to find the Part Number and Description from the components list. Please let us know.

2. General Precautions when using the equipment

- a. Before using the equipment, be sure to read the user manual and basic principles, usage and safety precautions for your awareness.
- b. When not in use, pull the parking break so that vehicle may not move. Connect the gear to neutral and place wedges so that the tires may not move.
- c. When you move the P.T.O, you should definitely press the clutch fully. If you hear sound from the Transmission, please check and request it to the dealer. If the sound occurred and you use it continually it might break the P.T.O and Transmission.
- d. Before you operate the Equipment, always get out the Beam of the outrigger and get down the outrigger cylinder. In particularly, you must check it to the ground surface outrigger cylinder very well.
- e. During the operation of Equipment, expert operator is only allowed to the operation limits.
- f. Do not operate equipment around the high tension as this is so dangerous.
- g. Prior rotating the Boom, make sure that there is no dangerous things beside it when you rotate it. (Especially building, signboard, high tension, peoples etc...)
- h. People should not pass around the equipment. Follow the instructions as prescribed.
- i. When you're driving the Aerial lift Truck, you should duly reach the Boom Rest and the Boom should always fold.
- j. Never use the Boom from pulling something.
- k. Please do not operate the Equipment from the front of the Truck CAB.

3. Composition and Specifications

A. Main composition and functions

- 1) This Aerial lift Truck composed of basic parts like middle frame, X-type front outrigger, rear outrigger, turn table, 7 stages boom & one boarding platform, all these parts should have a proper installation for maintenance level.

- 2) Main composition has various functions, the left-right 350° operation (boom rotation), withdrawal operation & leading in operation. These functions deals with the producer of Oil pressure power which have the Oil pressure pump and Oil pressure system. This handling operation refer to outrigger self examination and Usage of Wireless Remote Controller.

<Diagram of Equipment Composition>

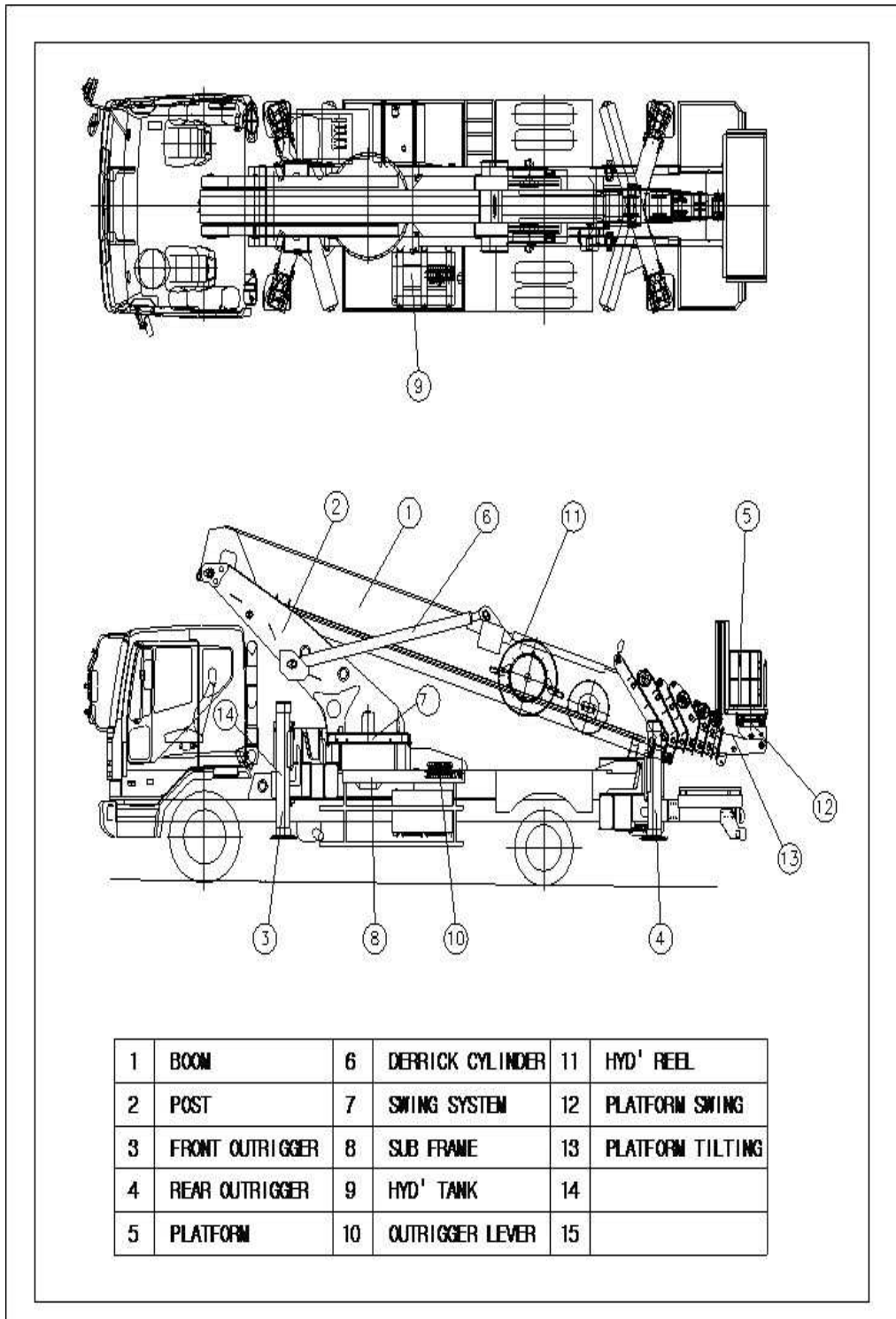

B. Features of HS 4570

ITEM		UNIT	HS 4570 PLUS
Vehicle on board			DAEWOO 5ton
Features	Height	mm	3920
	Width	mm	2495
	Length	mm	9670
	Gross Weight	kg	15950
Boom	Stage		7 Stages
	Shape		Octagon
	Withdrawal Type		Extension at the same time(2+4) - individual operation
	Quality of the material		High tensile structural steel (ATOS80)
Outrigger	Type		X TYPE, Device Hydraulic
	Withdrawal Width	mm	7634(Front), 7634(Rear)
Work scope	Withdrawal Height	m	45
	Withdrawal Weight		2 persons or 300kg
Turning gear	Type		Hydraulic Motor (Mechanical reduction gear - Double decelerator) TYPE
	Turning angle		Left and Right 350°
Boarding Platform	Size		3190 X 1140
	Turning Type		Hydraulic Motor Type (Mechanical reduction gear)
	Turning angle		Left and Right 2 rotations
Controlling device	Outrigger		Lever Type, Left and Right Type
	Boom		Wireless Remote controller
Convenience Device			Night Search Light, Remote Starting On/Off, Electronic Type Axel, Automatic Oil Cooler, Toolbox
Safety Device			Rollover Caution Safety, Over Center Valve, Pilot Check Valve, AML Safety
Options			

C. Diagram of Equipment Composition

The size and shape of the Equipment content details basically refer to 5 ton Truck.

While the driver still moving, make sure you fully understand the correct maximum height before and after the operation.

In particular, the driver operation will be determined after verifying that it is safe to pass for below overpass, telephone pole side, inside storage, tunnels or obstructions such as large construction sites prior entering the height and width.

Names and functions of equipment for each area described in the following, please refer to equipment configurations.

<Diagram of Equipment Appearance>

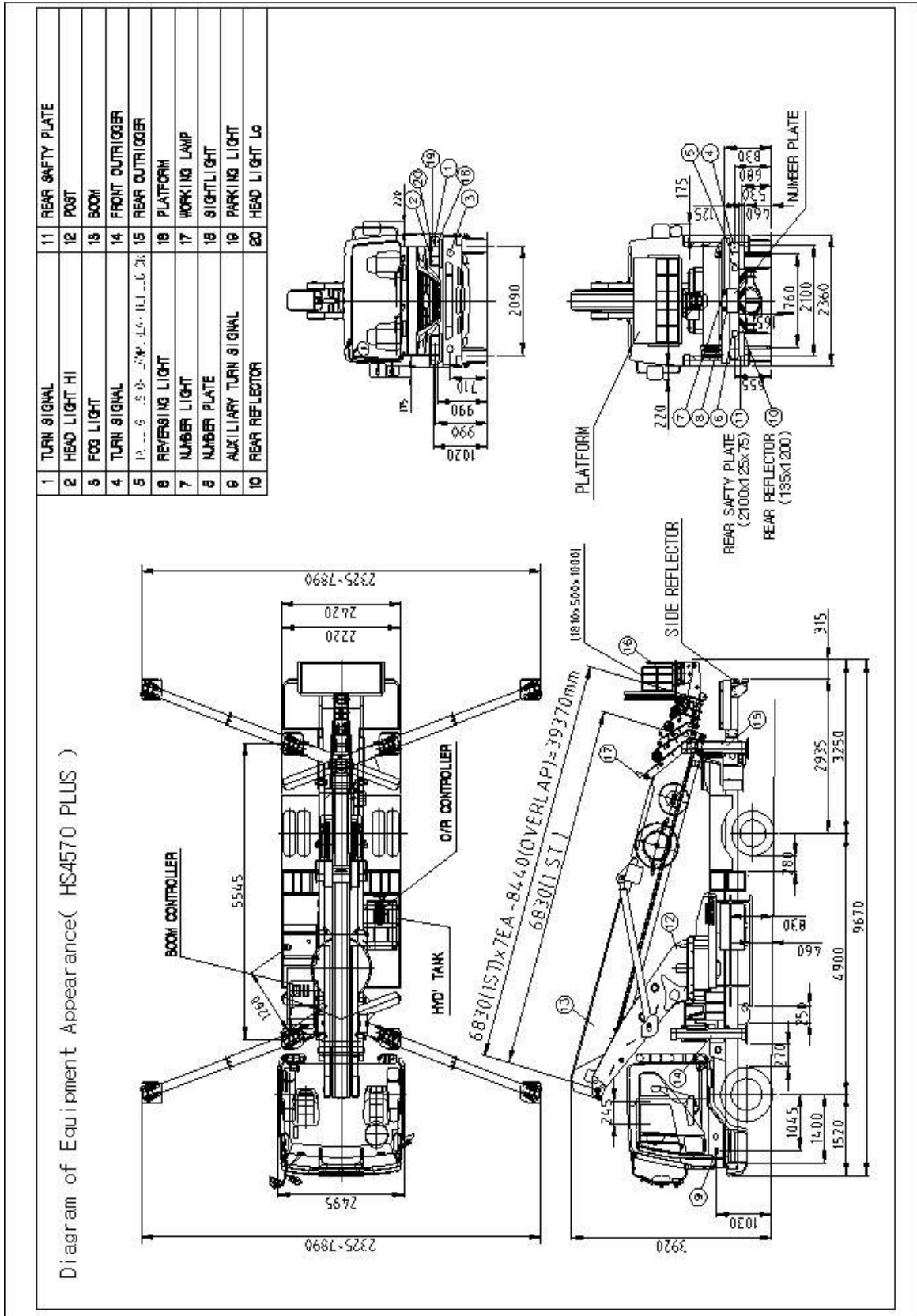

<Working Radius Diagram>

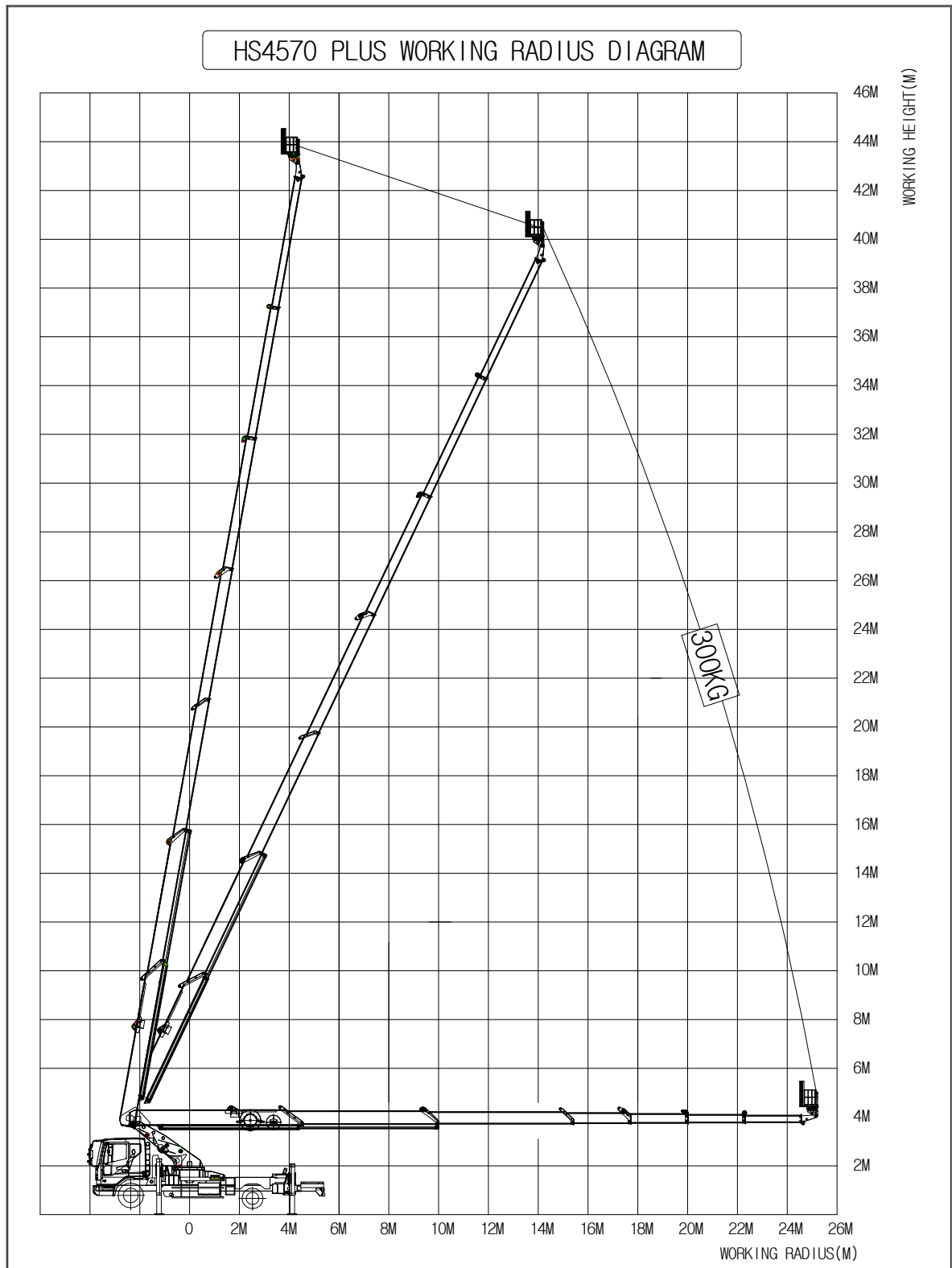

<Hyd' Component & Circuit>

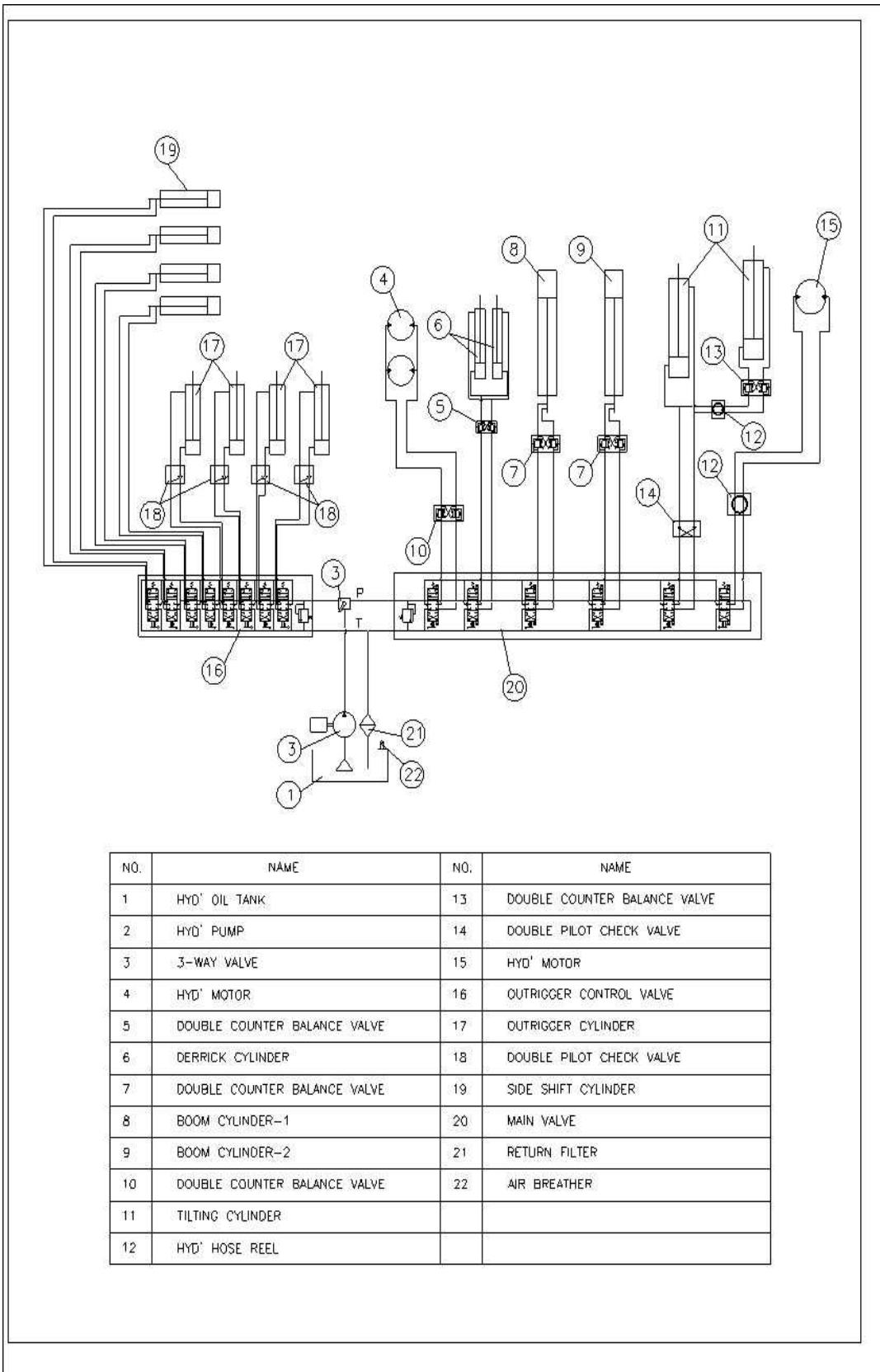

<Connective Diagram of Electricity>

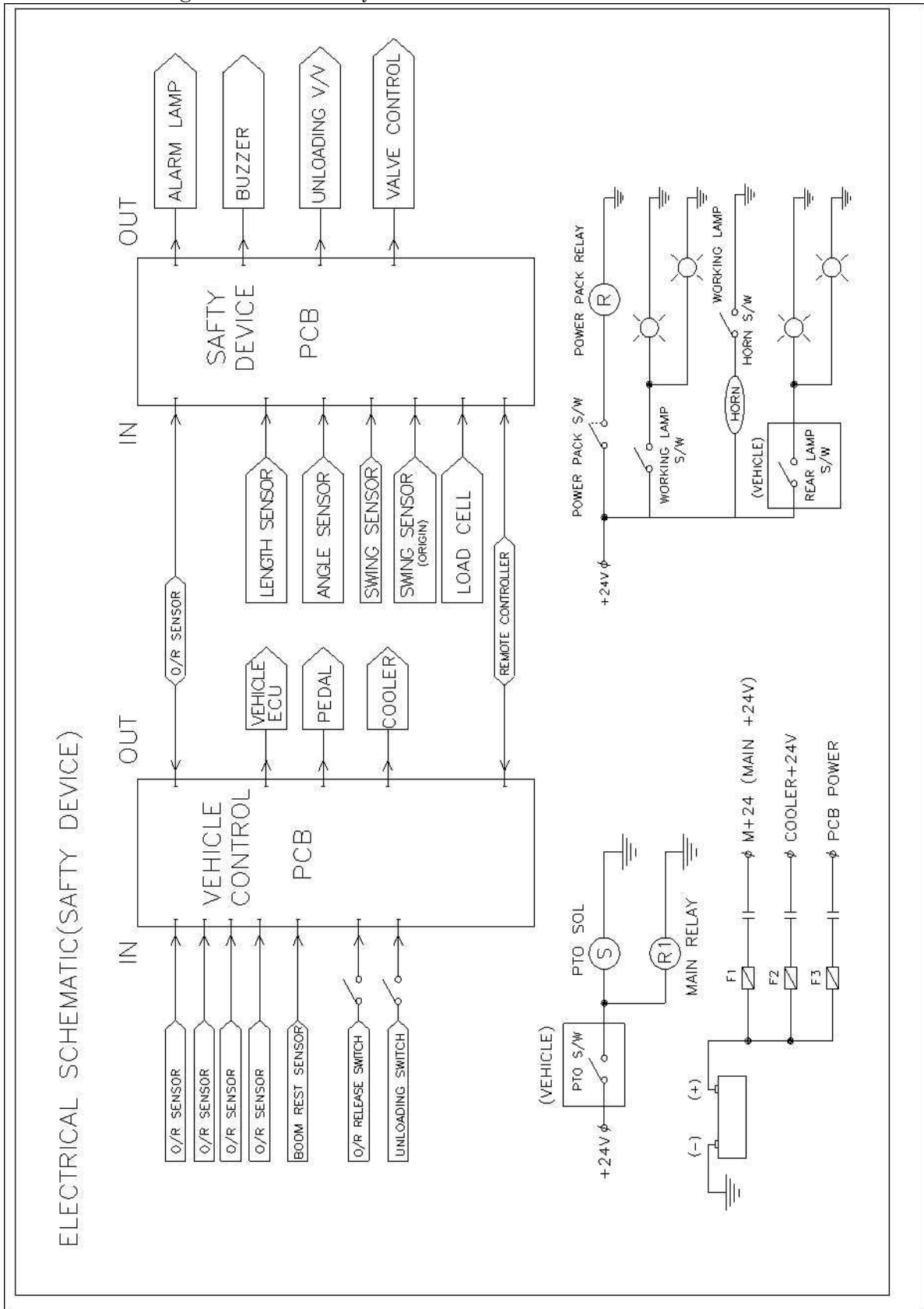

<Connective Diagram of Electricity>

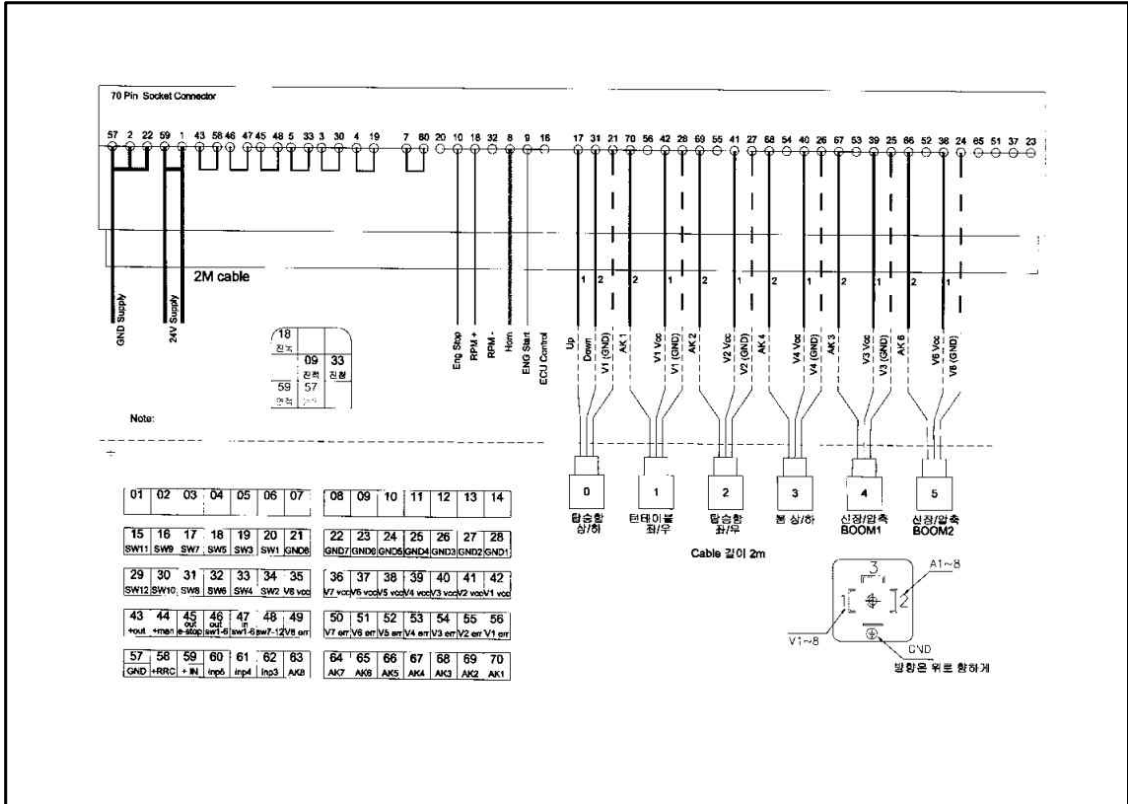

리모콘 송신기

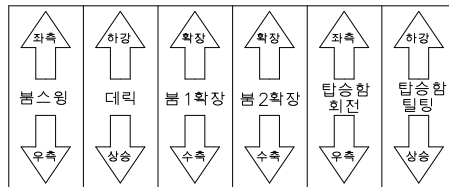

메인 밸브

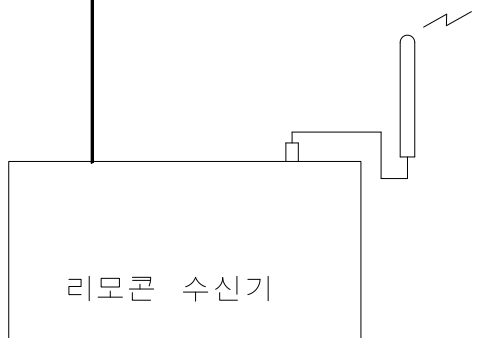

Safety Rules

This Equipment will have a good performance, if you do it right.

During the equipment operation, in order to prevent safety accident, be sure to follow the basic rules and regulation.

So, the operator takes all the responsibilities to follow the basic safety regulation for people and equipment.

The operator should have no doubt in concerned to warning device and safety device of equipment.

Not following the safety regulation may resulted to safety accident.

You either required to master the operation sense too.

The operator need to follow the safety regulation as well as duty to forestall the safety accident while doing the equipment operation.

A. Precaution before Operation

- 1) Always park in a flat and solid or paved road place where you can pull the parking break.
- 2) Without interfering obstructions in the working area go to a near place where you can find easy access.
- 3) Without moving the vehicle, it is possible to perform many task at any route.
- 4) Put a wedge under the wheels of the vehicle to prevent accidents while working in a sloppy areas.

B. Precaution of Outrigger Operation

- 1) Properly install the outrigger on the floor.
- 2) To ensure stability, spread the outrigger beams as much as possible.
- 3) The installation should be firmed to get in touch with the outrigger cylinder support.
- 4) Within the inclined position of the truck, put down the lower end outrigger following the higher outrigger to ensure vehicle horizontality.
- 5) If the area to be used anywhere is uneven or soft ground you should have competent support.
- 6) Due to slippy situation while the vehicle shaking, put the wedges carefully to prevent from falling down.
- 7) When operating in a soft ground, put down the outrigger and place a wedges. then check the condition of ground.

C. Precaution of Operator

- 1) Read the instructional manual and maintenance instructions, to familiarize yourself with the operation.
- 2) Operator must have a proper training to build enough experience prior operation of the equipment. to prevent harmful illness such epilepsy or seizure you should take early medication, any physical disabilities may damage the operation. It is your responsibility to perform self examinations to maintain calmness and good health.
- 3) Be safe in you working area before operation, the road should be safe either, you should check it from time to time.
- 4) Check the initial operation of all equipment devices as well as the driver brakes properly.
- 5) Check the equipment condition with your naked eye everytime if the equipment have damage condition, whether its from the structural part of the conclusion or whether there are oil leakages and looses of bolts or pins, make sure to take immediate action.
- 6) Seat belts and straps must be checked before the operation as per safety rules.
- 7) Equipment preventive maintenance must be checked daily, however the lubrication should be conducted regularly prior defect of the equipment. If damage occur, stop the operation.
- 8) Do not operate the equipment when the there's a bad weather condition such as severe wind or heavy fog.
- 9) People are not allow around th workplace, building, etc. as they were surrounded by some ground or objects which cause unsafe condition so always put barricade caution when start the operation.
- 10) Please be reminded, to check the warning devices at all times, neglect to pay attention should be involved in any safety violation which may cause people and equipment accident.
- 11) Daily checking of controls must be check for any abnormality condition, do not step on boarding platform before using the equipment.
- 12) There will be no assurance for modifications of equipment that can cause people damage and structural defect
- 13) Stay away from any electrical wires and secure a safety distance when operating the equipment.

D. Precaution of Equipment Operation

- 1) Only certified operator must operate the equipment.
- 2) While working on board platform, seat belt and belt strap must properly wear.
- 3) When heavy item is loaded on the boom and boarding platform, be careful not to exceed. (2 persons or 300 Kg) Do not load that exceeds the limit.
Excessive weight may cause deterioration of the equipment function or safety accident.
Please comply with the standards.
- 4) If the boom remote control have electrical jamming or any disconnection, switch on the emergency power of the transmitter. You must take this action the problem will no longer occurs.
- 5) Stop and prohibit the operation if you experience bad weather conditions. Below were as follows.
 - During heavy rain
 - During heavy snow.
 - During thunder and lightning storm
 - By ambient conditions such as fog, when the visually impaired
 - When the wind speed exceeds 10m/sec
- 6) .Check the passenger's safety prior operation of the equipment.
- 7) Avoid passing on the boom, and do not come in and out on the boarding platform.
- 8) When operator comes in the boarding platform, the boom should reach the bottom of the ground so that the boarding platform will also reach the ground floor, through that, the operator must be able to go on boarding.
- 9) When you ride down on a boarding platform into the ground, you must be specially careful on the lever operation
- 10) The equipment operator access all the action as possible

- 11) Do not change the boom speed randomly.
- 12) Do not exceeds the limits of the operation.
- 13) Operator should maintain stable condition to operate the operation. Do not use ladder, planks or other tools to reach the location.
- 14) Movement of vehicle or outrigger manipulation where there are people on the board should absolutely prohibited as the boom spread.
- 15) Prohibit the booms or boarding platform by pushing or pulling objects.
- 16) Workers inside the boarding platform including stuff aboard must be careful from falling down.
- 17) Be careful from moving the boom around the person or obstacles.

5. Operation and Usage of HS 4570

A. Operation preparation

- 1) Hold the hand brake of the car.
- 2) Check the proper amount of oil tank. (prudent hydraulic pressure oil)
- 3) Press the clutch of the vehicle and connect to the PTO gear. (the gear should be in a neutral position)
- 4) While the PTO is rotating, check for any noise condition.

B. Equipment preparation in hard winter

During winter time, the hydraulic pressure oil gets lower that's why viscosity temperature gets lower as well, continuing the operation may damage the hydraulic component.

- 1) Turn on the gear of PTO engine. As the engine rotates slowly, do not press the AXEL.
- 2) Turn on the engine for about 10 minutes, however do not operate the control lever.
- 3) 3-WAY V / V lever to move toward the outrigger position.
- 4) Push the two sides of front outrigger levers within 4-5 minutes.
- 5) Check the hydraulic oil tank with your hand, the temperature should be in lukewarm condition when operating the boom.

C. Equipment Operation of Function Section

- 1) PTO method operation.
 - a) Press the clutch if the gear in neutral standing position. Press "ON" the PTO switch and make sure dashboard light is turn on.
 - b) If you hear some noise. Press the PTO switch "OFF" and then PTO switch "ON". If the noise still occurs, please contact the dealer and the A/S. Use it after solving the problem.
- 2) Outrigger method operation.

Outrigger have two configuration , the 2 front outrigger and the 2 rear outrigger control valve formation is composed by the terminals.

A) Step by step procedure during the installation.

1) Withdrawal of outrigger INNER BEAM.

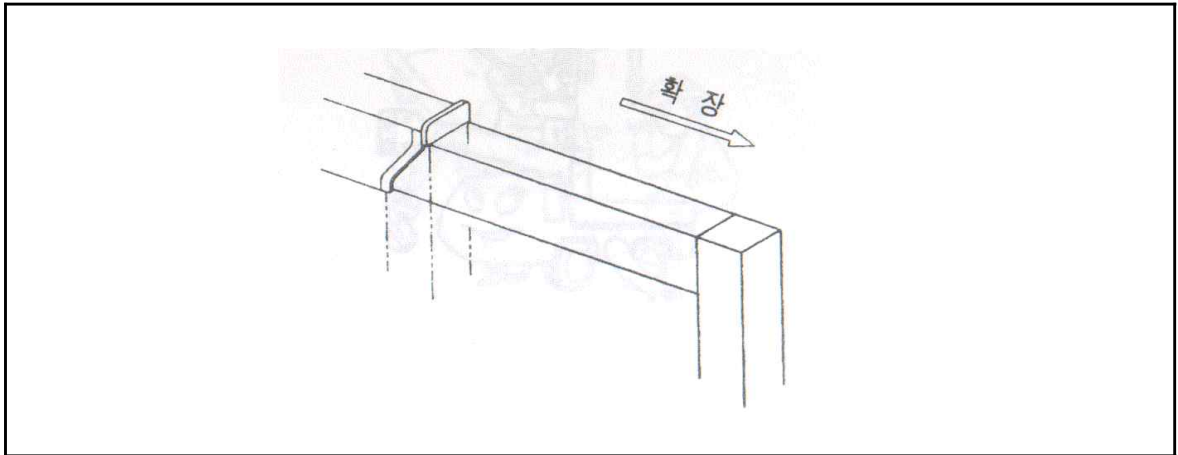

b) Please keep the vehicle horizontally while the outrigger levers direction moves decrease.

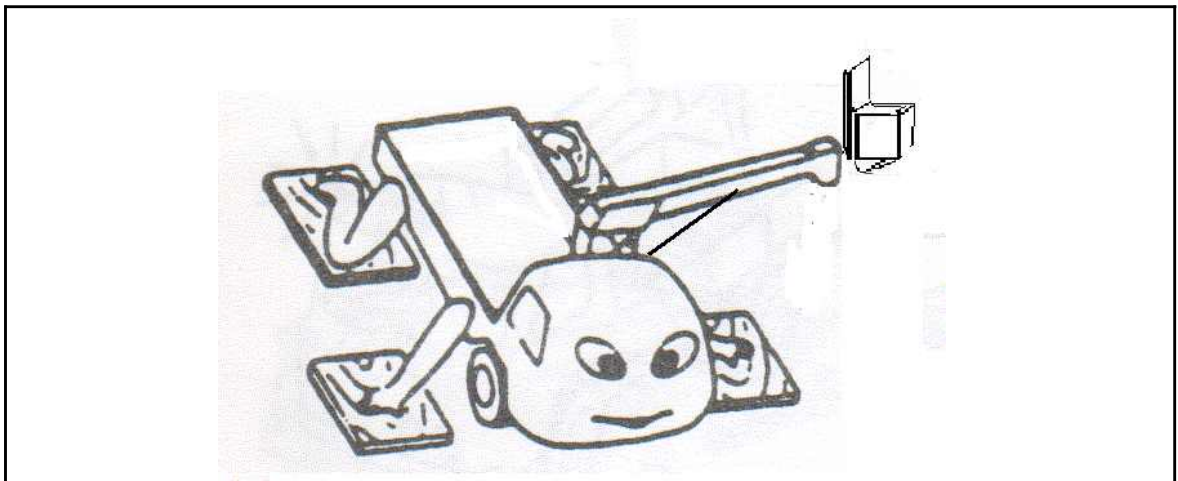

* Caution

- Check the ground condition avoid slope areas and soft ground before installing the outrigger
- Move out the inner beam outrigger to the maximum level to guarantee stability.
- To obtain horizontality of vehicle control lever, manipulate the outrigger cylinder properly.
- Outrigger cylinder withdrawal should prohibit the vehicle wheels from moving out. except from special circumstances. (Board spring power lift height is adequate)

B) Installation evacuation order of operation

ㄱ) Outrigger cylinder by operating the lever side operation to fully rise to contraction

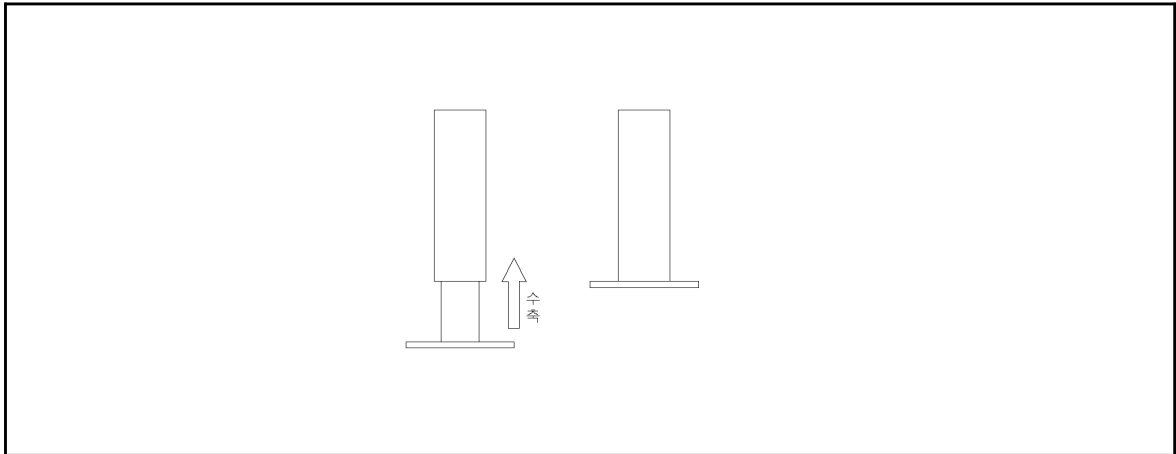

ㄴ) Check whether your withdrawal Inner Beam attached by the inlet.

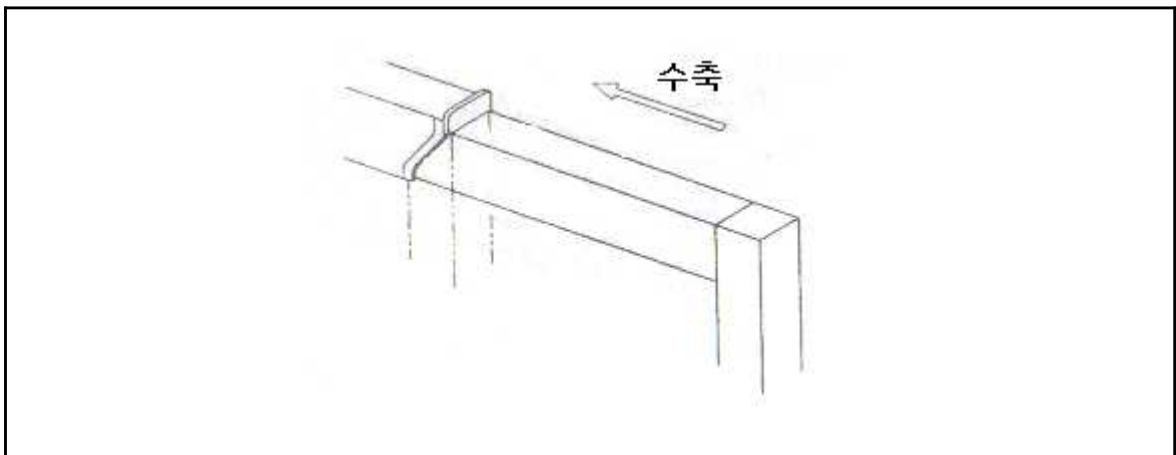

* Caution

- When moving from the vehicle and the cylinder is not completely shrink, it may cause damage, because of the presence of the bumps and smooth stone figure together with other object. Please go after fully contracted.

3) Switching direction valve (3-WAY V / V) method of operation

3 -Way valve supply direction of the hydraulic flow to the outrigger and boom.

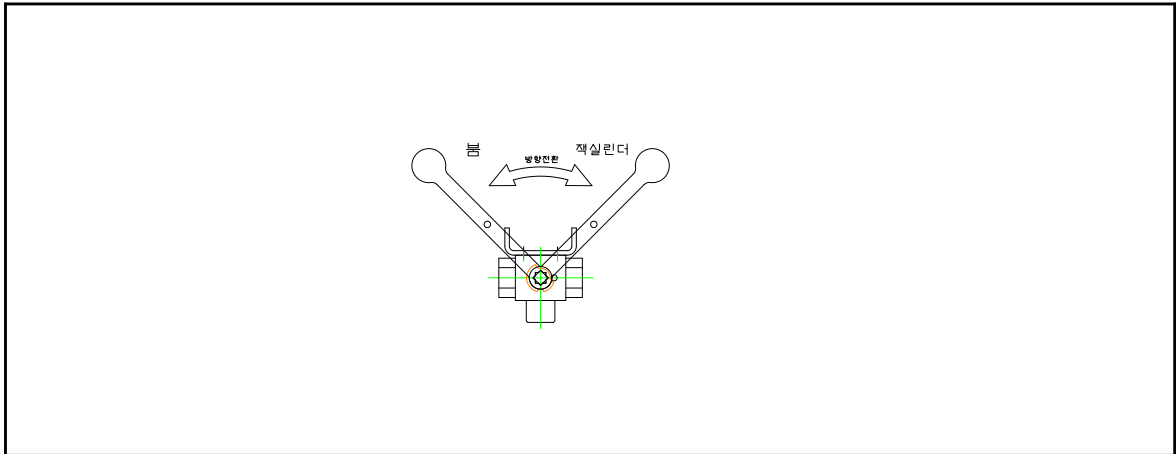

A) The operation sequence

- a) When operating the outrigger, the lever to locate the "Outrigger" in the indicated direction.
- b) When operating the Boom, the lever to locate the "BOOM" in the indicated direction.

B) Caution

- a) When spreading or operating the boom, the transition valve prohibit towards Outrigger as this is extremely dangerous.
- b) Entirely up to the point where you operate exactly.

4) Manipulating remote control to boom

A) Overview

Equipment operated by a wired and wireless remote control equipment.

B) Diagram composition of component



C) Remote controlling console operation method

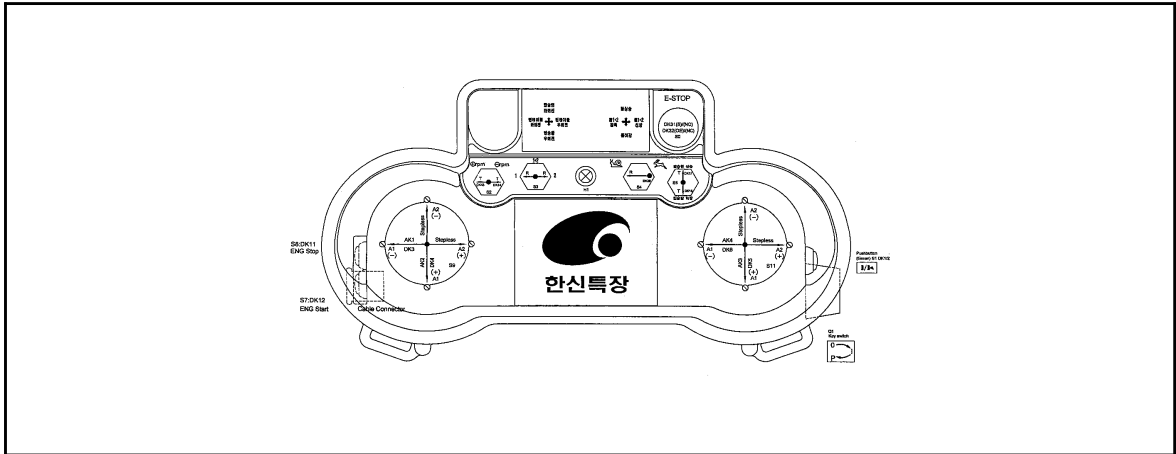

<explain controlling console>

Controlling	operation method & function explanation
Main power	<ul style="list-style-type: none"> - Power supply and protection of ON : Remote control operation switch on the power supply. OFF : Remote control switch has blocked the operation of the power supply.
Boom operation switches	<ul style="list-style-type: none"> - Increase / Decrease operation of the Boom Increase : Increase of the Boom Decrease : Decrease of the Boom
Boarding Platform operation switches	<ul style="list-style-type: none"> - Rotating operation of the boarding platform left : boarding platform rotates counter-clockwise right : boarding platform rotates clockwise.
EXT. Boom operation switches	<ul style="list-style-type: none"> - EXT. Withdrawal of the boom, the incoming operation Withdrawal : The Boom is withdraw Leading in : The Boom is leading in
SWING operation switches	<ul style="list-style-type: none"> - Rotation of the boom turning operation left : The boarding platform rotates counter-clockwise right : The Boom rotates clockwise.

Controlling	operation method & function explanation
Boom 1+2 operation switches	- Boom 1+2 operation switches 1 : Boom 1 operation 2 : Boom 2 operation 1+2 : Boom 1+2 synchronous operation
RPM operation switches	- RPM operation switches + : RPM increase - : RPM decrease
Emergency switches	- Emergency operation switches Press : block all functions (power supply cut off) Release : Emergency Power Off function is disabled
LAMP	orange flickering : while the operation of functions or detect frequency orange fixations : while the working standby of frequency fixations red flickering : battery exchange red fixations : Pressed the emergency switch

* Caution

-The receiver connector to used only while other connector plug in when using remote control.

Please make sure to unplug the connectors when using the remote control.

- Check the connectors if properly plug in to position, if you unplug the connector do not hold or lose the wires.
- Power supply switch attached each side of the receiver and transmitter one by one, simply turn "On" two switches when using.
- Check whether the connector is in good condition if you're unable to use the remote control, even if disconnection of cables and wires are in contact of the skin, check for any damages.
- Operating switch will be broken if you apply excessive force, please manipulate it gently.
- When using the wireless remote control, press the emergency switch in the event of malfunction due to interference. If this occurs, stop the operation.
- Wireless remote control mode is transmitted to propagate the battery, you cannot operate if there is no enough battery voltage, you must required to have spare battery charges so you can able to do the operation.

5) Handling method of the Boom

A) Check point before handling of the Boom

- Please make sure boom around interference obstacles.
- Vehicles supporting points 4 points (2 points forward , backward 2 units) of full contact with the ground outrigger. Please check out this condition.
- Please check the boom operation for any risk factor found.
- After thinking about working boom trajectory, you should focus on the operation

B) Handling of the Boom

- Boom operation using remote control to manipulate toggle switch with desired direction followed by job shuttle control side manipulation, start with the opposite side while the MAX volume slowly stop, where the MIN volume adjusted gradually. Please do it in with no move at all.
(Quickly start and finish the operation due to the shock and over shake of the boom, please use caution as possible.)
- During operation of the boom, the boom rises up and rotate after that you can do operation.
- By manipulating the boom, the lower boom operates on work locations.
- Conversely, when the boom moves down from vehicle, it moves orderly from top.
- The boom during operation with reference to that radius, action must be done within the limit scope

* Caution

- Do not operate the outrigger cylinder as the people on boarding platform during boarding.
- Avoid contact with the high voltage lines, when operating the boom.
- The boom rotates 175° on both sides, however do not exceeds more that specified limit, do not rotate beyond cap direction, you rotate the boom up to the rear vehicle only.
- Safety belt attached to the boom with other parts of the hydraulic system, tampering is extremely prohibited.
- You may start to drive after you exactly reach the boom rest.
- When you operate the boom, the workers must properly hold the handle.
- The driver must observe the environment at all times when working.
- Boarding platform worker assures that all doors must be locked prior working.
- When you operating the boom be sure to have balance and do it slowly.
- Below illustration must strictly prohibited during the operation.

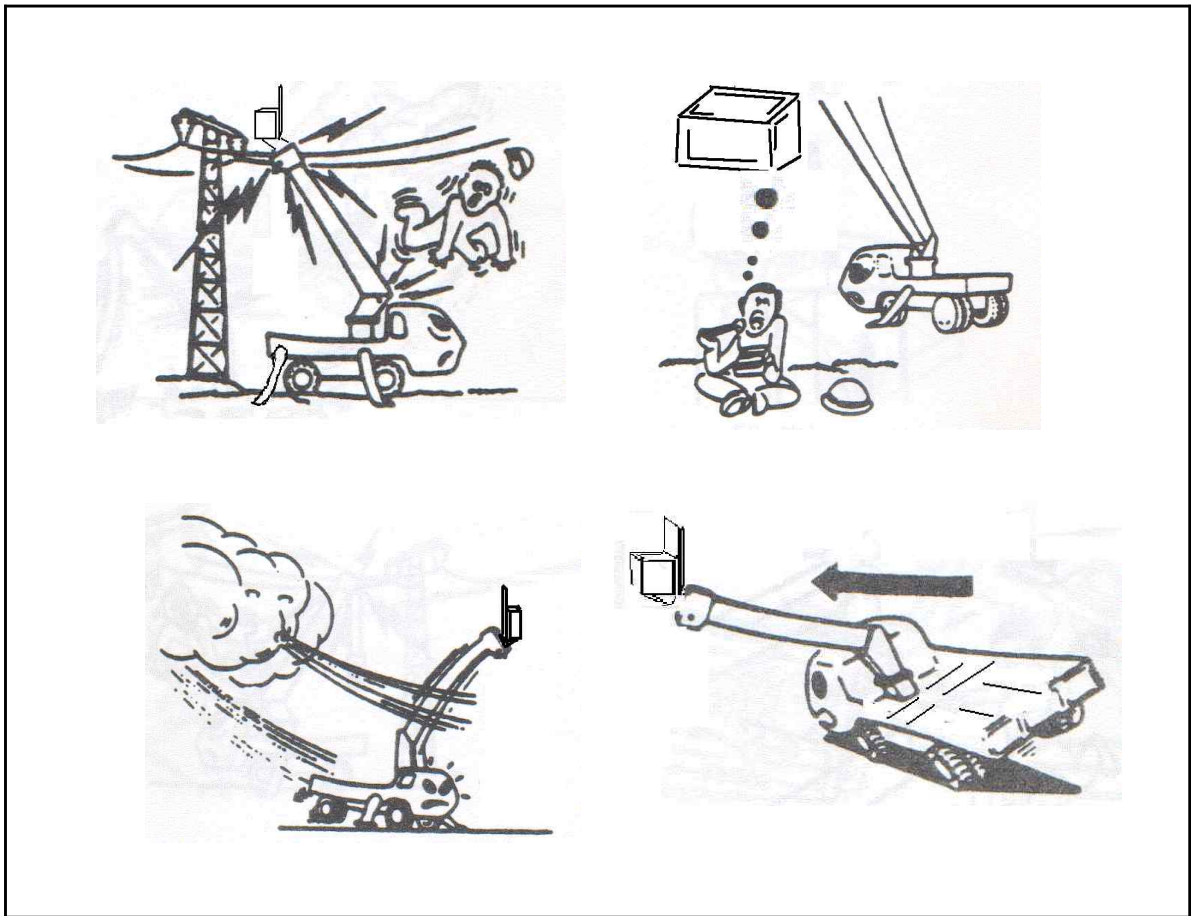

C) Handling procedure

- 3-WAY V / V switch in the direction of the boom .
- Operate the boom slowly to desired position.

6) Handling method of the emergency equipment

- If the vehicle engine cannot use, the emergency equipment will be used for rescue in department boarding.
- Press ON the emergency switch as well as remote control lever .

7) AML operation

- If the outrigger is not maintain on the ground firmly, you cannot operate the main boom after switching the 3-WAY valve.
- After the operation, if do not entirely move the boom rest down you cannot do outrigger operation after switching the 3-WAY valve.
- Be able to operate if within the safety scope limit, you cannot operate if out of the safety scope limit as AML moves.
- Allowable weight limit (300 kg) for bench, over the limit the all operation will stop.

6. Repair Precaution & Examination

The primary complain occurring in the operation is mainly because of mechanical parts and hydraulic parts problem.

Mechanical difficulties appears in each boom, CRACK occurred in other structures and destroy, etc, hydraulic defects is hard to find, so check them well.

A. Check Points before Operation

- A) Is hydraulic pressure oil in the oil tank sufficient?
Fill the Hydraulic pressure oil less than the minimum. (In this case less than the middle of Oil pressure gauge on the tank)
Inspection of Hydraulic pressure oil check the outrigger on refold.
- B) Isn't there oil leakage from connecting parts such as hydraulic pressure hose, pipe, valve or cylinder?
Damage pipes and hoses need to replace, when poor connection make it tighten.
- C) Is there crack or damage of the structure?
- D) When the control lever operates well and put the lever, is it back to neutral position?
- E) Is it good to operate the valve, when operating the remote control?
- F) Isn't there loose or damage from connecting parts, bearing and bushing, shaft, pin etc?
- G) Isn't there damage of wires and cables?

B. Check Points during Operation

- A) Is there leakage of hydraulic pressure oil?
- B) Is there generation of suspicious noise during operation?
- C) Isn't the temperature of hydraulic pressure oil very high?
- D) During boom operation, does lifting of outrigger foothold appear in phenomenon?

C. Check Points after Operation

- A) Is the condition good as much as the next operation?
- B) Is there crack or damage of the structure?
- C) Isn't there oil leakage from connecting parts such as hydraulic pressure hose, pipe?

D. Check Points after 1month Operation

- A) Is there change of pressure?
- B) Is there leakage of oil ?
- C) Isn't there smooth bolt and screw? (Check U-BOLT)
- D) Isn't there smooth from connecting parts such as hydraulic pressure hose, pipe?
- E) Is there move the locking installations properly?
- F) Is there move the control valves properly?
- G) Isn't there broken parts of wire cable?
- H) Is there crack or damage of the structure?
- I) Is hydraulic pressure oil in the oil tank sufficient?
- J) Isn't there generation of suspicious noise during operation?

E. Check Points after 6months Operation

- A) Disinfect the outer surface of the Hydraulic pressure cranes.
- B) Is there change of pressure?
- C) Is there leakage of oil ?
- D) Isn't there smooth bolt and screw? (Check U-BOLT)
- E) Isn't there smooth from connecting parts such as hydraulic pressure hose, pipe?
- F) Is there move the locking installations properly?
- G) Is there move the control valves properly?
- H) Isn't there broken parts of wire cable?
- I) Is there crack or damage of the structure?
- J) Is hydraulic pressure oil in the oil tank sufficient?
- K) Isn't there generation of suspicious noise during operation?
- L) Is the pump and hydraulic pressure parts in proper connection?
- M) Please exchange the filter.
- N) Is the condition of the hydraulic pressure oil good?
Please replace the color of hydraulic pressure oil if the color change to black or white.
- O) Please check the infusion state of lubrication then put oil.

F. Lubrication

Below section expresses lubrication using grease gun every 20 hours operation.
The kind of lubricating oil is extreme-pressure grease. Rating is EF # 2.

* Grease Infusion parts

- Boom post and 1 Boom connection parts - 1 piece filling
- Swing bearing parts - 2 pieces filling
- Boarding platform cylinder parts - 1 piece filling
- P.T.O and journal bearing parts of PUMP connection drive shaft - 2 pieces filling
- Extension Boom withdrawal parts
- Swing bearing gear

G. Examination & Exchange of the hydraulic pressure oil

1) Examination of the hydraulic pressure oil

The amount of hydraulic pressure oil of the equipment should be check every time.

The amount of oil appear in the flow meter of oil tank shown in below photo.

Therefore, the amount of the hydraulic pressure oil shows over $2/3$ on flow meter transparent tube it is on proper state.

If the hydraulic pressure oil is full it's in overcharge case and if the hydraulic pressure oil below $1/2$ it's in shortage case.

When you check the amount of oil on the flat land, the boom and the outrigger must fully folded. Where there is insufficient amount of hydraulic pressure oil in the current oil tank, refuel the tank with same hydraulic pressure oil.

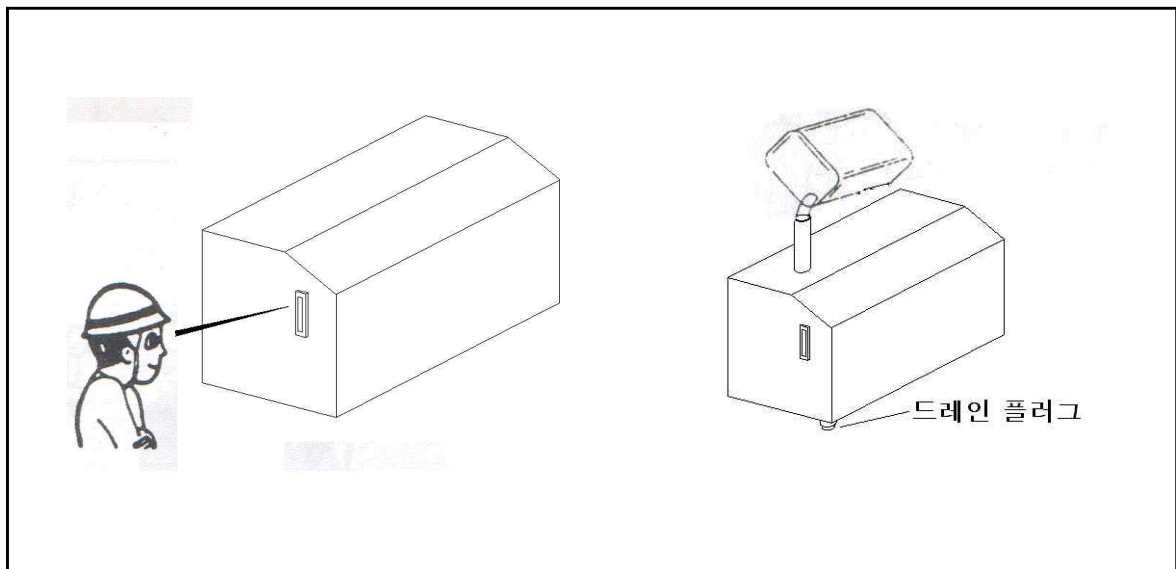

* Check condition of the hydraulic pressure oil

Appearance	Status	Measures
It is transparent and no change of colors	Good	Continues
It has discolored	The bubble or water is mixed	Water Separation (oil maker) Or exchange oil.
It has turned dark brown	Oxidation is depleted	Exchange
It is transparent and has small black spot	It is mixed with other dust or dreg.	Use by filtration or exchange oil.

2) Exchange of the hydraulic pressure oil

Changes of hydraulic pressure oil must be once a year at least.

The hydraulic pressure oil should not be contaminated because this can damaged the hydraulic component.

When you purchased the vehicle and operate it for one month and 100 hours change the hydraulic pressure oil through above list and macrography.

* Precautions for replacement and exchange of hydraulic pressure oil

- Replacement and changes, the surroundings must be clean and prevent contamination of other substances.
- When replacing, loosen the drain plug, when drains it all, clean inside of the tank using completely clean cloth or other tools, when done inject new oil.

3) Usage of hydraulic pressure oil

Specification	ISO VG 46(Cryogenic region : ISO VG 32)
---------------	---

* Caution

- When using the oil, this oil use to satisfy both the viscosity classification and quantity classification.
- When checking up and changing the oil inject to identify capacity (ℓ).
- Do not mix other oil or chemicals on hydraulic pressure oil.
- Please change completely new oil when replacing hydraulic pressure oil.
- This is to remove the content air in the hydraulic pressure oil.
- If the content air in the hydraulic pressure oil, Seal may be damaged

H. Exchange & Examination of the filter

Return filter eliminate the impurities of hydraulic pressure oil into the tank and influence the smooth flow of hydraulic fluid, it plays important role so this should make necessary examination and change on time.

A) Examination matters

- Checking the status of the leak connection parts
- Checking of negative pressure rises : separate measure to pressure gauge

B) Exchange matters

- First, completely shut down the operation of installation, after 5-10 minutes operate the pressure light device in safe condition.
- To maintain cleanliness around should be cleaned thoroughly .
- Please loosen, hand or power tool . (When changing filter, remove excess hydraulic fluid flow to replace the filter quickly)
- After changed, be careful not to loosed as this is fully tightened.

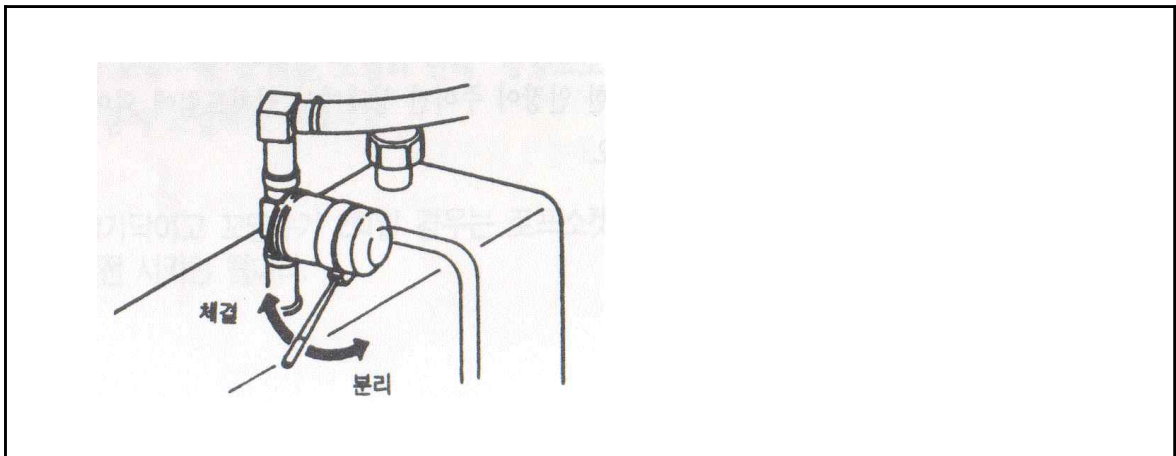

I. Examination cylinder

1) Descent of Outrigger cylinder

Outrigger cylinder influence a very large safety when design of installation, this should need maintenance inspections thoroughly.

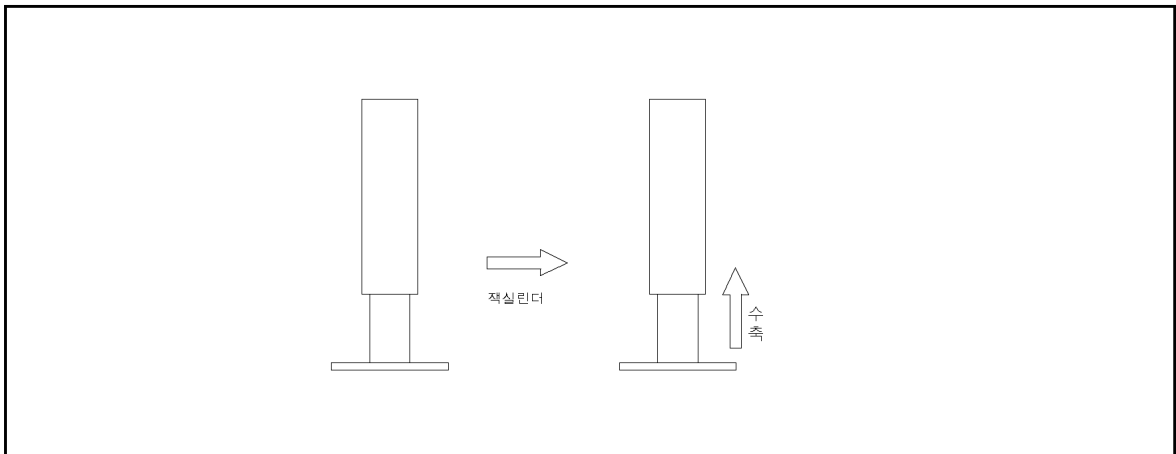

① Examination method

- Operate the outrigger in appropriate location(about 10 mm locations , ink etc. used in load), turn off the engine in maximum rise state.
- After marking and 10 minutes please check descend status. (2 mm or less shrinkage)

② Caution

- Please stop the operation when quickly descend during operation as other cylinder might be descend at the same time.
- If problem exists, please contact the company and the A/S.

2) Derrick cylinder normal descent

- When operation, derrick cylinder directly link to safety of worker and beforehand please do maintenance inspections.

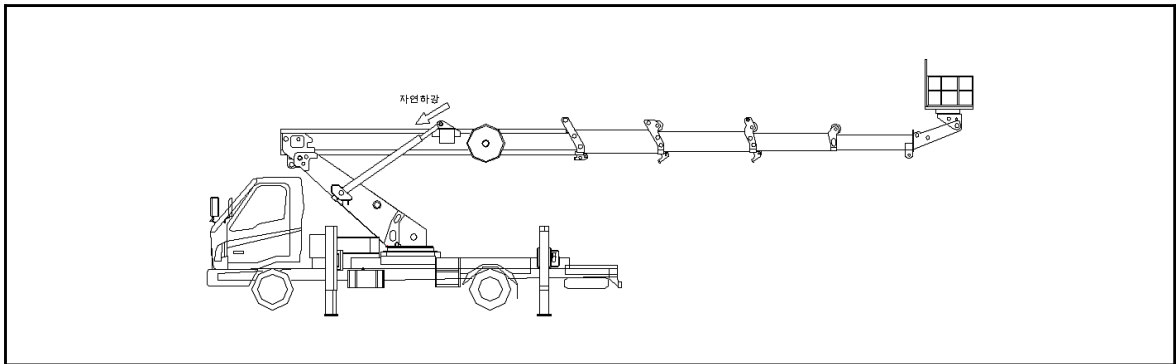

① Examination method

- 1/3 of the boom is out and 1 step boom is located parallel with the vehicle, the tube and the load of derrick cylinder crack, mark to use ink etc.
- After marking and 10 minutes please check descend status. (2 mm or less shrinkage)

② Caution

- Please fold each step when quickly descend during operation, 1 step boom should be elevated.
- If problem exists, please contact the company and the A/S.

3) Extension cylinder normal descent

① Examination method

- 50-60kg objects to be load on the boarding platform, mark the appropriate location of each stage of contraction and expansion of the boom. (two stages and three , three stages and four)
- After marking and 10 minutes please check descend status. (3 mm or less shrinkage)

② Caution

- Please stop the operation when quickly descend during operation and operate the contraction direction.
- If problem exists, please contact the company and the A/S.

7. Malfunction & Measurement

If problem occurs when using Aerial Lift Truck follow below measures depending on the cause of failure, for more information please contact the dealer and the A/S.

Item	Problem	Cause	Measures to take
Inst allat ion	Engine run but the Equipment don't run	P.T.O poor connection	Does the P.T.O gear work normally with the mission gear(check sound)
		Hydraulic pressure oil lack	Hydraulic pressure oil replenishment
		Pressure of the valve is lowness	Modification setting pressure of the relief
		Damage of the pump	Repair or exchange of the pump
P T O	P.T.O does not operate	Breakage & disconnection P.T.O handle switches	Exchange & check normalcy of the Puse Check connection & disconnection of the cable
		Mixing an air from connecting parts the vacuum line	Reassemblage & Exchange of the parts
		Damage vacuum magnetic valve	Exchange of the parts
		Be stopped vacuum inlet port	Check the inlet port
	Damage P.T.O gear arm & gear	Exchange the parts	
	P.T.O occur noise	P.T.O connection poor	P.T.O operate again
		Bearing & Gear damage	Exchange & change the parts
The gear oil shortage		The gear oil supplement	
P U M P	Noise occurrence on the pump & Poor operation of hydraulic pressure	Shortage of the hydraulic pressure oil	Supplement of the hydraulic pressure oil
		Mixing an air from connecting parts of suction pipe(hose)	Repair connecting parts
		Be relaxed of the bolt fixed	Be fixed the bolt strongly
		Be caught the dross at strainer	Exchange & clean the strainer
		Broken inner gear	Exchange & change the parts
		Broken pump case	Exchange & change the parts
B O O M	Boom does not operate overall	Pressure lowness of the relief valve	Modification setting pressure of relief (3-WAY V/V upper)
		Broken relief valve	change
		Shortage quantity of hydraulic	Supplement hydraulic pressure oil
		Lowness the efficiency of pump	Repair & change
		Be stopped the cable of remote	connection
		Ground connection the cable of remote	reconnection
		Poor MAIN SOL valve	check short-circuit of parts the cable
			Exchange when damage the product
		Poor remote receiver	Check condition of the power supply(FUSE & CONNECTOR)

Item	Problem	Cause	Measures to take
B O O M	function parts poor connection	short-circuit of the cable	Cable reconnection
		SOL. valve poor operation	Repair & change the component
			Valve at the top left& right of the electrical CONNECTOR changed by assemble, electric or defects of the valve decide to take a step
	Leakage and function component breakage	Remote control poor	Repair the remote control
		Plumbing assembly parts leakage	Reassemble to use assemble tools
		cylinder leakage	Component change
hose damage		Change (preliminary inspection)	
R E M O T E	overall poor operation	main power supply disconnection	Reconnection of disconnection parts
		receiver PUSE short-circuit	Change
		ground wire short-circuit	Reconnection of short-circuit parts
		Main SOL. valve cable short-circuit	Reconnection of short-circuit parts
	poor operation of each function parts	short-circuit of the cable	Reconnection of cable
		SOL. valve poor operation	Repair & change the component
		Poor relay	Change the relay
		Poor control switches	Inspection & change
	when the special function operation occur continued	Ground connection the cable of function parts	Reconnection of cable
		SOL. valve poor operation	Repair & change the component
	Dismantle the valve and use after clean the spool parts		
O U T R I G E R	The cylinder doesn't increase	shortage of the hydraulic pressure oil	Supplement the hydraulic pressure oil
		Foreign substance is caught into valve or packing poor	After dismantle clean & repair
	Decrease when the load	Check valve poor	Repair or change
		Inner of cylinder leakage	Repair or change
	During operation the leg descend	Check valve poor	After dismantle clean & repair
		Inner of cylinder leakage	Repair or change
		Exterior of cylinder leakage	Repair or change